

Operating and technical manual

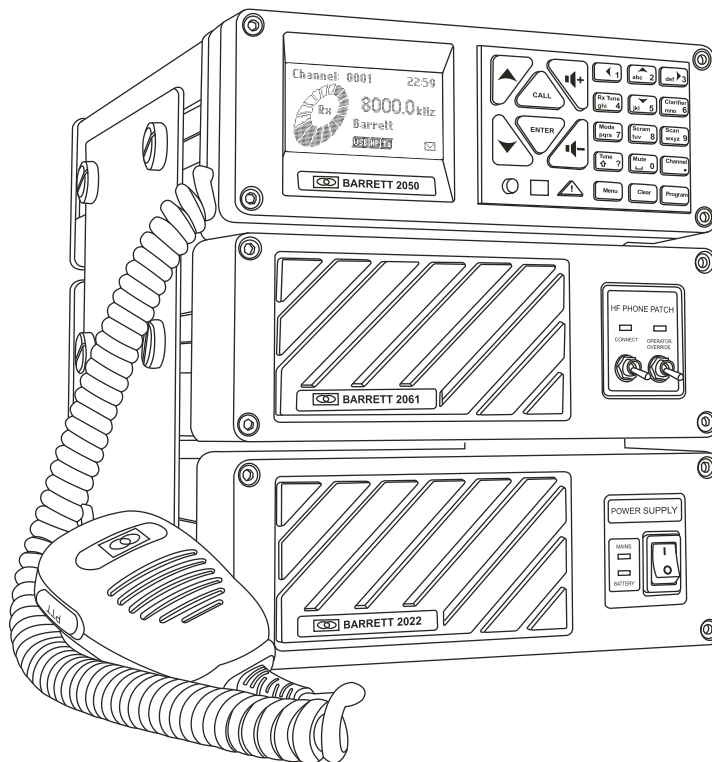

BCM20601/7

© Barrett Communications

Head office:

Barrett Communications Pty Ltd
47 Discovery Drive, Bibra Lake WA 6163 AUSTRALIA
Tel: +61 8 9434 1700 Fax: +61 8 9418 6757
Email: information@barrettcommunications.com.au

www.barrettcommunications.com.au

Specifications

Output level to phone line	Nominally -0 dBm
Input level from phone line	Nominally -0 dBm
Frequency response	300 to 3000 Hz \pm 2 dB
Output impedance to phone line	600 Ω
VOX sensitivity	Adjustable internally
VOX hang time	0.5 seconds
Ultimate hybrid balance	-50 dB measured with a single tone

Transceiver interface

Rx audio input	Balanced 600 Ω @ 0 dBm
Tx audio output	Balanced 600 Ω @ 0 dBm
Frequency response	300 to 3200 Hz \pm 2 dB
VOX key output	Open collector
Switching speed	5 mS

General

Telephone line connector	RJ-11C
Local telephone set connections	RJ-11C
Connector to transceiver	DB-25
Indicators	"CONNECT", "OPERATOR OVERRIDE"
Front panel controls	"CONNECT", "DISCONNECT", "OPERATOR OVERRIDE"
Rear panel control	Monitor volume control
Input power	+11 to +15 VDC (12VDC nominal)
Input current	80mA @ +12.6 V input
Size	185mm W x 270mm D x 70mm H (2000 series standard enclosure)
Weight	0.8kg

Environmental

Operating temperature	-20°C to +55°C
Storage temperature	-40°C to +85°C
Humidity	Up to 95% @ 55°C
Shock	MIL-STD-810D, method 516.3 procedure VI
Vibration	MIL-STD-810D, method 514.3 Category

Overview

The Barrett 2061 HF telephone interface (phone patch) provides an interface between an HF network and the international telephone network, allowing HF stations to be connected to telephone subscribers and vice versa.

The HF network user provides the base station operator with the telephone number required. The operator dials the number on the telephone connected to the 2061 interface unit. When the telephone subscriber answers, the station operator switches the 2061 to "CONNECT". The automatic VOX is activated and the call between the HF network station and the telephone subscriber proceeds automatically, the transmitter being keyed by the telephone subscriber's voice. During the call the station operator can speak to both parties by using the "OPERATOR OVERRIDE" switch. At the completion of the call the station operator switches the 2061 to "DISCONNECT".

The Barrett 2061 uses a unique adaptive hybrid to convert the four-wire audio from the transceiver to two-wire audio for the phone line. An adaptable hybrid, implemented with digital signal processing (DSP), provides continually recalculated isolation between the off air HF signal and the telephone user, producing a reliable VOX signal (Voice Operated Xmit (transmit)) to key the transmitter when the telephone subscriber's voice is present.

The 2061 is packaged in a 2000 series patch enclosure and is designed for direct interface via our standard bus cable to the Barrett 2050 transceiver. It can however be interfaced to other suitable HF transceivers.

Features

DSP based automatic adaptive hybrid that balances the telephone line continually with no adjustments, eliminating oscillation in full duplex circuits, false VOX tripping and time consuming setup.

Designed for full-duplex, half-duplex, or simplex operation.

Compact desk-top package.

Built-in speaker with volume control to monitor call progress

Connection to Barrett 2020 power supply and 2050 transceiver

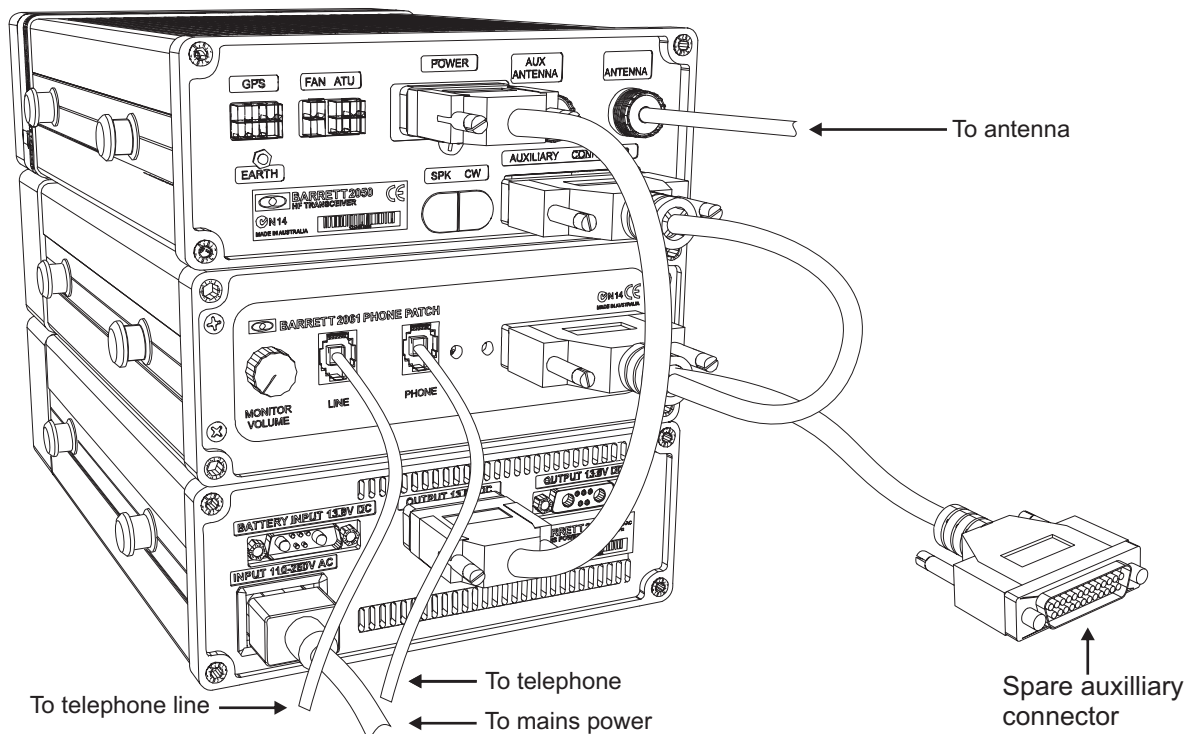

Operation

Front panel controls and indicators

Operator override switch

This switch operates the key relay in the 2061 to cause a connected transmitter to transmit. The transmitter is keyed automatically by the VOX and the operator override LED is turned on when the switch is pressed upward.

Connect switch

This switch controls the connection of the 2061 to the telephone and audio circuits. When the switch is in DISCONNECT position, the telephone line is disconnected from the unit and patched through to the telephone hand set, and the audio in/outs are disconnected. Thus the 2061 is effectively out of the circuit.

When in the CONNECT position, the phone line and the audio are connected to the 2061 and the connect LED will light. The unit then starts its adaptation cycle of the phone line. When the adaptation cycle is complete, the unit is ready for operation.

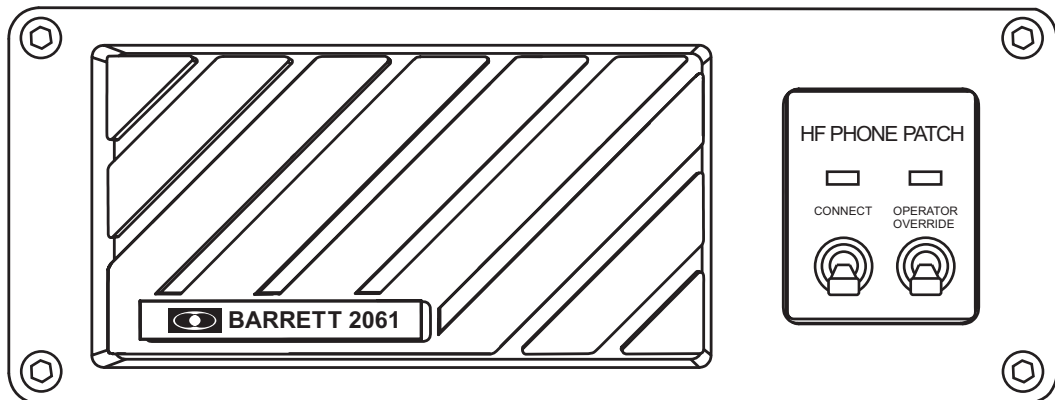

Rear panel controls and indicators

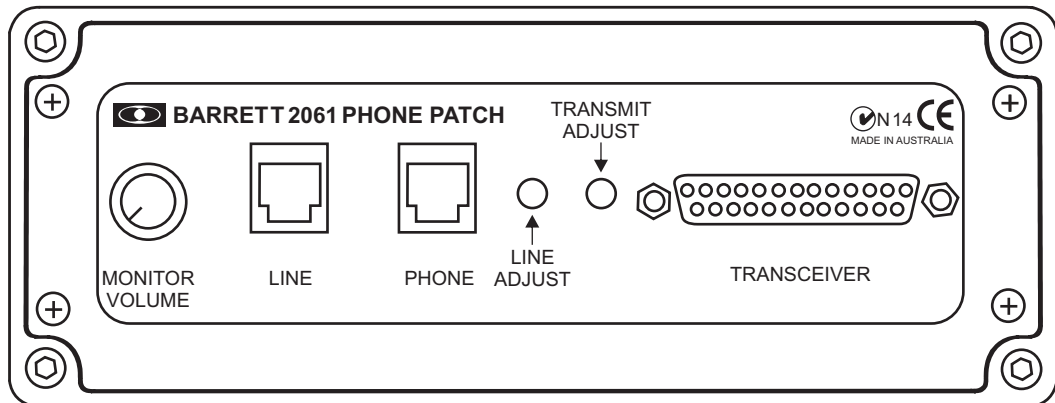

“Transceiver” connector

This is the connector for the interface between a radio system and the 2061. It contains transmit and receive audio and keylines.

“Line” connector

This RJ11C provides the telephone line connection. When the unit is in CONNECT mode, the telephone line is switched to the 2061 phone patch circuitry. When the unit is in DISCONNECT mode, the 2061 is bypassed and the telephone line is routed to the PHONE connector.

“Phone” connector

This RJ11C jack allows the connection of a telephone set (telephone) to 2061. The telephone is connected to the telephone line when the 2061 is in the “DISCONNECT” mode. When the unit is switched to “CONNECT”, this jack is disconnected from both the line and the unit until the Operator Override Switch is used.

“Vox Adjust”

This is a screw type pot which allows the VOX sensitivity to be adjusted. See Section “Transmitter keying (VOX)”

Line Adjust

This is a screw type pot allowing the transceiver audio to line level to be set. This should be set at a level where there is sufficient receive audio at the phone users end.

“Monitor Volume”

This control adjusts the monitor speaker volume in the 2061.

Operation examples

Telephone subscriber connecting to an HF network station via the HF base station equipped with a 2061 telephone patch

The 2061 telephone patch is in the "DISCONNECT" mode and the operator at the base station is speaking to the telephone subscriber wishing to be connected to the distant HF station.

The base station operator call the distant HF station using Selcall or ALE

When contact is established between the base station operator and the distant HF station, the operator informs the two parties that he is about to connect the two and selects "CONNECT" on the 2061

The 2061 automatically adapts itself to the phone line and the link is established between the HF station and the telephone subscriber. The transmitter is keyed automatically by 2061 which derives the VOX signal from the telephone subscribers voice using DSP.

Progress of the call may be monitored via speaker on the 2061 and when communications is complete, the operator switches the 2061 to DISCONNECT. The link is disconnected.

The HF network station is to be connected to a telephone subscriber on the international telephone network via the HF base station equipped with a 2061 telephone patch

The HF station on the network contacts the HF base station and tells the operator the number of the telephone subscriber that he wants to be connected to.

With the 2061 telephone patch is in the "DISCONNECT" mode the base station operator dials the number on the phone connected to the 2061. Once he is talking to the telephone subscriber he informs both parties he is about to connect and selects "CONNECT" on the 2061.

The 2061 automatically adapts itself to the phone line and the link is established between the HF station and the telephone subscriber. The transmitter is keyed automatically by 2061 which derives the VOX signal from the telephone subscribers voice using DSP.

Progress of the call may be monitored via speaker on the 2061 and when communications is complete, the operator switches the 2061 to DISCONNECT. The link is disconnected.

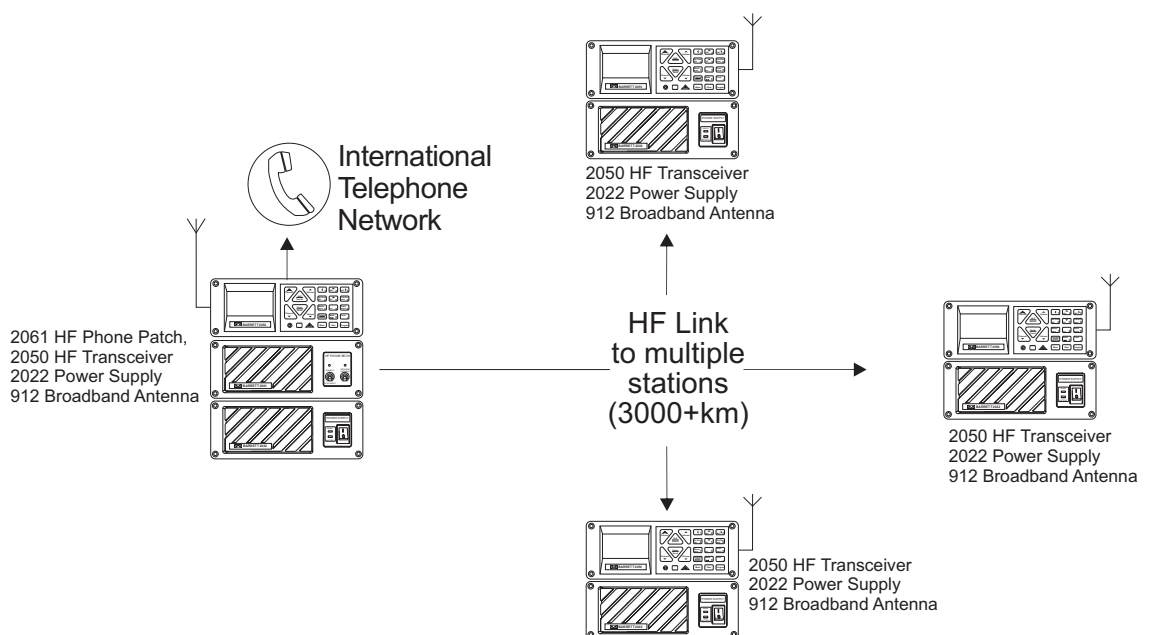

Transmitter keying (VOX)

For a normal link, the VOX in the 2061 is set up to key the transmitter. The VOX responds to signals on the telephone line and operates the keying circuits when voice is present. Once the VOX has tripped, it stays active for a short time following the loss of audio to prevent dropout on pauses between syllables. This delay is called VOX hang time.

The VOX in the 2061 is generated within the DSP and is extremely sensitive and reliable.

Adjusting VOX sensitivity

Where non-standard or poor quality telephone lines are used for connection to the 2061, adjustment of the VOX sensitivity may be necessary. This is achieved by adjusting the "VOX Sensitivity" pot rear of the unit using a small Philips head screwdriver. If the VOX sensitivity is too low (transmitter does not key reliably on voice), rotate the pot clockwise. If the VOX sensitivity is too high (transmitter keys on noise other than spoken words), rotate the pot anti-clockwise

Technical description

The basic blocks of the 2061 include a phone line interface, a transceiver interface, a hybrid, microprocessor and speaker amplifier. The connect switch and operator override and their corresponding LED's are to be found on the front panel and are connected to the main PCB via a loom connector (P7).

The phone line interface involves a line connect relay (RL1) which diverts the phone audio to either the hybrid, when the unit is connected, or to the handset. A second relay (RL2) has the function of placing both the handset and the hybrid on line during operator override, where the operator talks to both parties. A gyrator (Q4, Q5 etc) is situated between the line connect relay and the hybrid and is used for looping the line thereby informing the exchange that the line has been seized in the "CONNECT" mode.

The hybrid (U5) interfaces the phone line to the transceiver and has the primary function of canceling the reflected transceiver line audio. The hybrid is connected to the line via a simple resistor network and audio transformer. The transmit audio input and received line audio output connect the hybrid to the transceiver via a filter and various balancing/unbalancing audio amplifiers (U1, U2, U3). Adaption to the line is initiated by a microprocessor and takes around one second. During this time the transceiver line audio is muted via a FET (Q2). The algorithm is continuously adaptive, always trying to null the transmitted audio reflected by the line. A trimpot (POT1) is required to set the transceiver audio to the hybrid so that it is at an acceptable level for a caller. The second trimpot (POT2) sets the hybrid audio to transceiver and is also very important for setting the VOX level. Although setup in the factory this can be later adjusted after installation to cater for various line conditions.

The received line audio is converted to balanced audio for interfacing to the transceiver. One of these balanced outputs is passed through a precision rectifier (U3) and converted to DC for processing by a PIC microprocessor (U8). Thus the VOX state including the hang time can be determined and transceivers PTT line activated accordingly. Other functions of this microprocessor are to read the state of the switches, drive the state LED's, activate the relays and to initiate the hybrid balance sequence.

The speaker amplifier (U9) provides the operator with a mixed signal of radio operator and caller audio. Volume control is provided by a potentiometer mounted on the back (P6). To prevent acoustic feedback a muting switch (Q6) is automatically activated when the operator bypass is enable.

Connecting other HF transceivers to the 2061

Other HF transceivers can be connected to the 2061 telephone patch via the “TRANSCEIVER “ connector on the rear panel. Details of the signals available on this connector are shown on the table below:-

“TRANSCEIVER” connector (25 pin female "D" connector on rear panel)

Pin	Name	Description of function	Level
1	Ground	Ground	0V
2			
3			
4			
5			
6			
7			
8			
9	PTT Out	PTT output	Active low 0V
10			
11	Bal. Tx Out	Balanced Tx audio output (with pin 24)	600 Ω - Audio 24dBm to 0dBm
12	Bal. Rx Audio Input	Balanced Rx audio input (with pin 25)	600 Ω - 6dBm to +9dBm
13	Ground	Ground	0V
14			
15			
16			
17			
18			
19			
20			
21			
22			
23	+13.8 VDC Input	+13.8VDC input (+11VDC to +15VDC)	13.8VDC
24	Bal. Tx Audio Output	Balanced Tx audio output (with pin 11)	600 Ω - 24dBm to 0dBm
25	Bal. Rx Audio Input	Balanced Rx audio input (with pin 12)	600 Ω -6dBm to +9dBm

Parts Lists

2061P01-A3-Parts List

Designator	Description	Part Number
C1	Cap 10n 100V	CP-00032
C2	Cap 10n 100V	CP-00032
C3	Cap 10n 100V	CP-00032
C4	Cap 10n 100V	CP-00032
C5	Cap 100nF 5% 50V	CP-11666
C6	Cap 100nF 5% 50V	CP-11666
C7	Cap 100nF 5% 50V	CP-11666
C8	Cap 100nF 5% 50V	CP-11666
C9	Cap 100nF 5% 50V	CP-11666
C10	Cap 100nF 5% 50V	CP-11666
C11	Cap 100nF 5% 50V	CP-11666
C12	Cap 100nF 5% 50V	CP-11666
C13	Cap 100nF 5% 50V	CP-11666
C14	Cap 100nF 5% 50V	CP-11666
C15	Cap 100nF 5% 50V	CP-11666
C16	Cap 100nF 5% 50V	CP-11666
C17	Cap 100nF 5% 50V	CP-11666
C18	Cap 4n7 5% 50V	CP-11698
C19	Cap 4n7 5% 50V	CP-11698
C20	Cap 47uF 16v 10%	CP-11665
C21	Cap 47uF 16v 10%	CP-11665
C22	Cap 47uF 16v 10%	CP-11665
C23	Cap 47uF 16v 10%	CP-11665
C24	Cap 10nF 5% 50V	CP-11667
C25	Cap 1uF 5% 16V	CP-11674
C26	Cap 1uF 5% 16V	CP-11674
C27	Cap 1uF 5% 16V	CP-11674
C28	Cap 100uF 20% Electro	CP-11705
C29	Cap 100uF 20% Electro	CP-11705
C30	Cap 10uF Tant 16v	CP-01580
C31	Cap 10uF Tant 16v	CP-01580
C32	Cap 10uF Tant 16v	CP-01580
C33	Cap 10uF Tant 16v	CP-01580
C34	Cap 15pF 5% 50V 0603	CP-11687
C35	Cap 15pF 5% 50V 0603	CP-11687
C36	Cap 2u2 Tant 20V	CP-01620
C37	Cap 2u2 Tant 20V	CP-01620
C38	Cap 2u2 Tant 20V	CP-01620
C39	Cap 220nF 5% 50V	CP-11690
C40	Cap 470uF 20% Electro	CP-11719
C41	Cap 470uF 20% Electro	CP-11719
C42	Cap 1nF 5% 50V NPO	CP-11668
C43	Cap 100nF 5% 50V	CP-11666

Parts Lists

2061P01-A3-Parts List

Designator	Description	Part Number
C44	Cap 10uF Tant 16v	CP-01580
C45	Cap 10uF 16v Y5V	CP-11710
C46	Cap 10uF Tant 16v	CP-01580
C47	Cap 1nF 5% 50V NPO	CP-11668
CP1	Cap Net 1nF 50V NPO 5%	CP-11703
D1	Di ZHCS400	DI-03356
D2	Di ZHCS400	DI-03356
D3	Di BAV99	DI-03317
D4	Di BAV70	DI-03316
D5	Led Red SMD 0805	LE-02920
D6	Led Red SMD 0805	LE-02920
D7	Led Red SMD 0805	LE-02920
D8	Led Red SMD 0805	LE-02920
D9	Led Red SMD 0805	LE-02920
D10	Led Red SMD 0805	LE-02920
D11	Led Red SMD 0805	LE-02920
D12	Led Red SMD 0805	LE-02920
D13	Di BAV70	DI-03316
D14	Di GF1A	DI-03354
D15	Di GF1A	DI-03354
D16	Di GF1A	DI-03354
D17	Di GF1A	DI-03354
D18	Di BZX84C16 Zener	DI-03367
L1	Ind 10uH 1210	IN-03600
L2	Ind 10uH 1210	IN-03600
L5	Ind 10uH 3DF TOKO	IN-15007
L6	Ind 10uH 3DF TOKO	IN-15007
L7	Ind 10uH 3DF TOKO	IN-15007
MOV1	Varistor V120ZA1	VA-02530
P1	Conn RJ12 F 6W6C RA PCB	CN-24163
P2	Conn RJ12 F 6W6C RA PCB	CN-24163
P3	Conn DB25 F RA	CN-04132
P4	Plug 6 pin Polarised	CN-14106
P7	Header 10W Box	CN-04138
Q1	Trans 2N7002 LT-1	TR-02282
Q2	Trans 2N7002 LT-1	TR-02282
Q3	Trans 2N7002 LT-1	TR-02282
Q4	Trans BC847 SOT23	TR-02262
Q5	Trans BCP56-10 SOT223	TR-02236
Q6	Trans 2N7002 LT-1	TR-02282
R1	Res 270R 0.063W 5%	RE-10362
R2	Res 47k 0.063W 5%	RE-10326
R3	Res 47k 0.063W 5%	RE-10326

Parts Lists

2061P01-A3-Parts List

Designator	Description	Part Number
R4	Res 33k 0.063W 5%	RE-10318
R5	Res 180R 5% 0.063W	RE-10358
R6	Res 39k 0.063W 5%	RE-10322
R7	Res 39k 0.063W 5%	RE-10322
R8	Res 39k 0.063W 5%	RE-10322
R9	Res 22k 0.063W 5%	RE-10311
R10	Res 22k 0.063W 5%	RE-10311
R11	Res 100k 5% 0.063W	RE-10291
R12	Res 10k 5% 0.063W	RE-10277
R13	Res 10k 5% 0.063W	RE-10277
R14	Res 10k 5% 0.063W	RE-10277
R15	Res 10k 5% 0.063W	RE-10277
R16	Res 10k 5% 0.063W	RE-10277
R17	Res 10k 5% 0.063W	RE-10277
R18	Res 10k 5% 0.063W	RE-10277
R19	Res 10k 5% 0.063W	RE-10277
R20	Res 10k 5% 0.063W	RE-10277
R21	Res 10k 5% 0.063W	RE-10277
R22	Res 10k 5% 0.063W	RE-10277
R23	Res 10k 5% 0.063W	RE-10277
R24	Res 10k 5% 0.063W	RE-10277
R25	Res 10k 5% 0.063W	RE-10277
R26	Res 10k 5% 0.063W	RE-10277
R27	Res 30k 0.063W 5%	RE-10315
R28	Res 6k8 0.063W 5%	RE-10332
R29	Res 6k8 0.063W 5%	RE-10332
R30	Res 680R 0.063W 5%	RE-10329
R31	Res 3k3 0.063W 5%	RE-10323
R32	Res 220R 5% 0.063W	RE-10279
R33	Res 220R 5% 0.063W	RE-10279
R34	Res 220R 5% 0.063W	RE-10279
R35	Res 220R 5% 0.063W	RE-10279
R36	Res 220R 5% 0.063W	RE-10279
R37	Res 220R 5% 0.063W	RE-10279
R38	Res 220R 5% 0.063W	RE-10279
R39	Res 220R 5% 0.063W	RE-10279
R40	Res 220R 5% 0.063W	RE-10279
R41	Res 220R 5% 0.063W	RE-10279
R42	Res 220R 5% 0.063W	RE-10279
R43	Res 100R 5% 0.063W	RE-10283
R44	Res 10R 5% 0.063W	RE-10278
R45	Res 1R 0.063W 5%	RE-10310

Parts Lists

2061P01-A3-Parts List

Designator	Description	Part Number
R46	Res 68k 0.063W 5%	RE-10330
R48	Res 10R 5% 0.063W	RE-10278
R49	Res 82k 0.063W 5%	RE-10344
R50	Res 82k 0.063W 5%	RE-10344
R51	Res 330R 5% 1W 1218	RE-00238
R52	Res 3k3 0.063W 5%	RE-10323
RL1	Relay EA2-12 NEC	RL-05013
RL2	Relay EA2-12 NEC	RL-05013
RP1	Res Array 10k 5% 50v	RE-10303
T1	Transformer Midcom	TF-05129
U1	IC OP279GS	IC-20056
U2	IC OP279GS	IC-20056
U3	IC OP279GS	IC-20056
U4	IC OP279GS	IC-20056
U5	Hybrid	PO-07417
U6	IC LT1616ES6	IC-20008
U7	IC LM2660M	IC-20026
U8	IC PIC18F452 TQFP44	IC-20012
U9	IC TDA1905 DIP16	IC-20034
U10	IC ULN2003AD	IC-02717
VR1	Pot 10k Log	RE-02805
X1	Crystal 10Mhz QC49/S	CR-07652
2061P02-A1-Front Panel PCB Parts List		
Designator	Description	Part Number
P1	Header 10W Box	CN-04138
D1	Led Green 5x2 rectangle	LE-02909
D2	Led Green 5x2 rectangle	LE-02909

Barrett 2061 Phone Patch Schematics and PCB Overlays

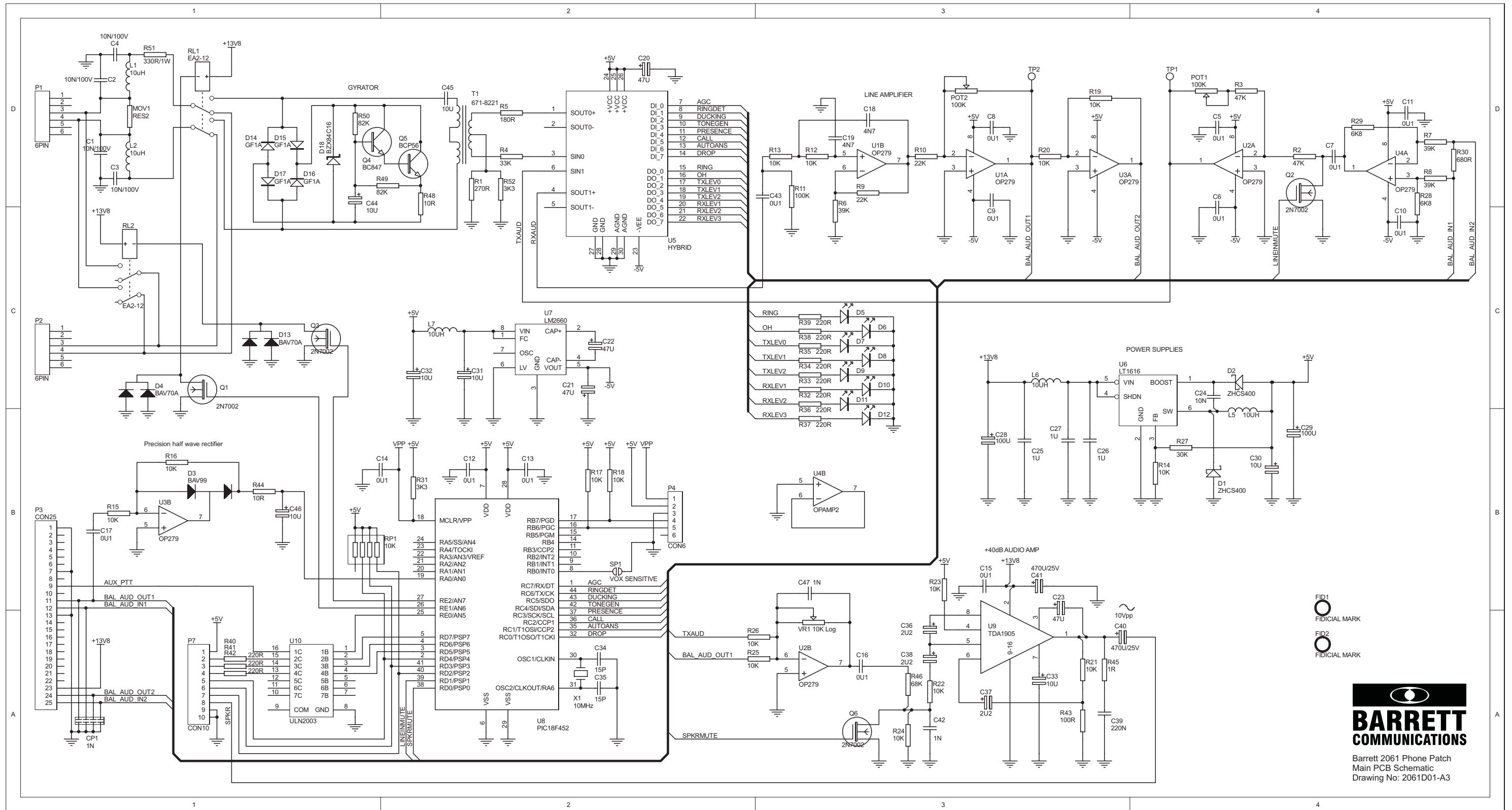

Barrett 2061 Phone Patch Schematics and PCB Overlays

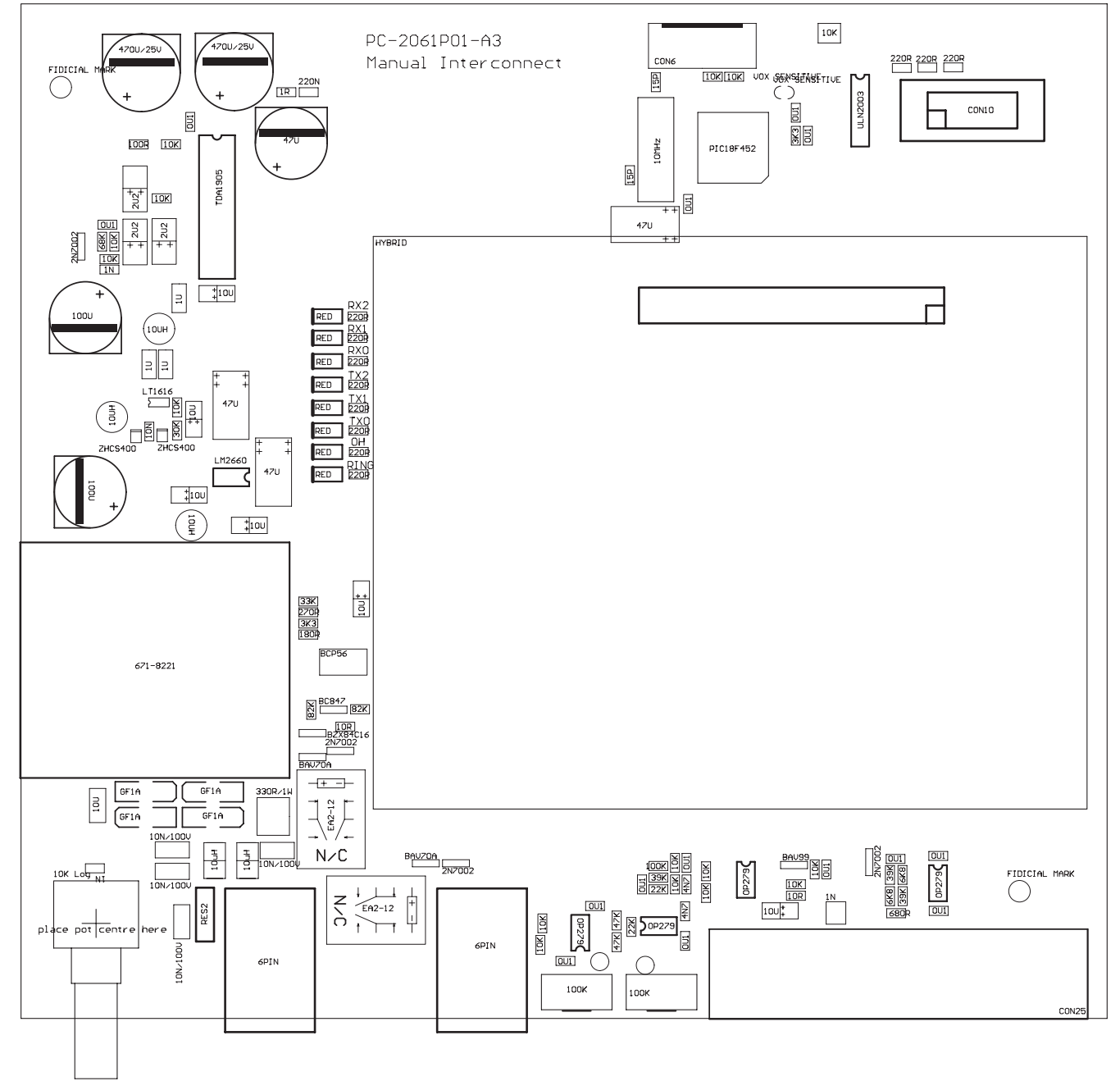
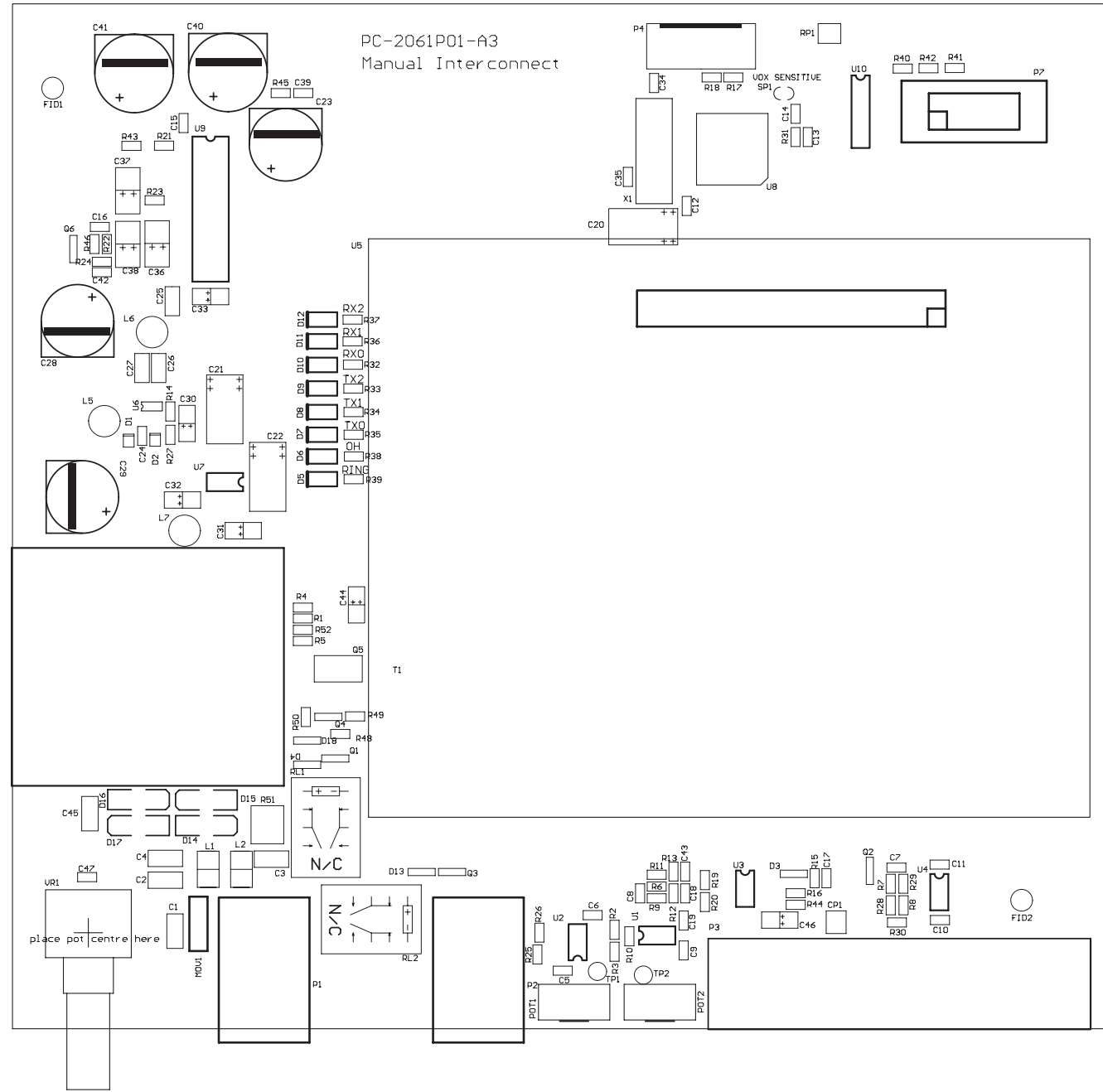

Barrett 2061 Phone Patch
PCB Overlay showing designers
Drawing No: 2061P01-A3



Barrett 2061 Phone Patch
PCB Overlay showing values
Drawing No: 2061P01-A3

Barrett 2061 Phone Patch Schematics and PCB Overlays

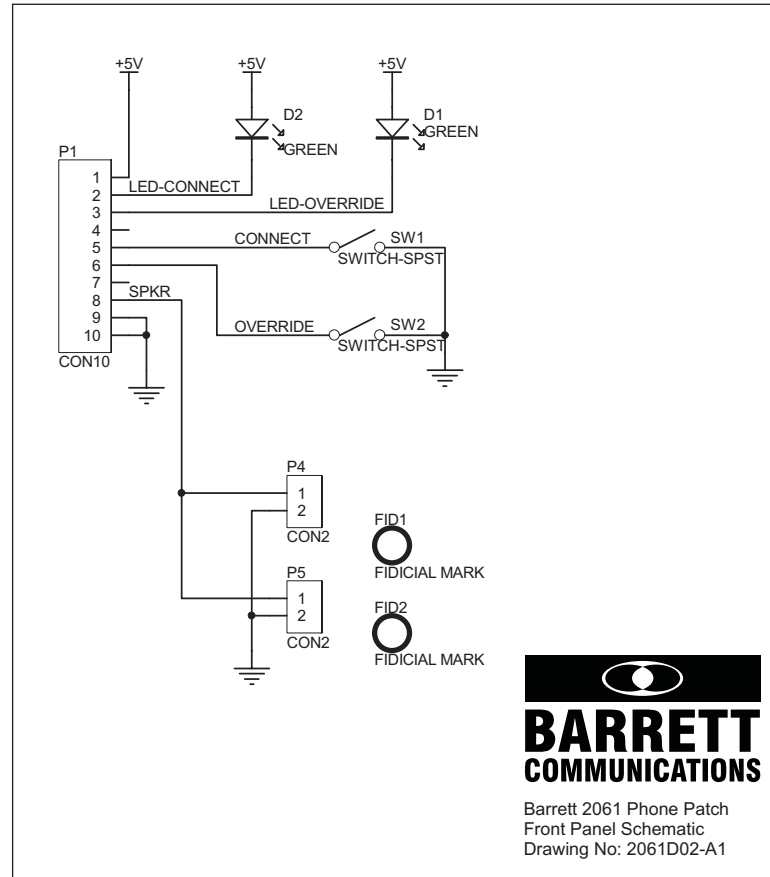

BARRETT COMMUNICATIONS
 Barrett 2061 Phone Patch
 Front Panel Schematic
 Drawing No: 2061D02-A1

